



# MedactaQTH

QUAD TENDON HARVESTING

QUALIFIED, TAILORED, HANDY



## Surgical Technique

Joint

Spine

Sports Med

**NOTE**

This document describes the Medacta Quad Tendon Harvesting Surgical Technique.

## INDEX

<b>1. INSTRUMENTS OVERVIEW</b>	<b>4</b>
1.1 Vertical Cutters	4
1.2 Horizontal Cutters	4
1.3 Subcutaneous Cutters	5
1.4 Vertical, Horizontal and Subcutaneous Cutter Combinations	5
<b>2. VERTICAL HARVESTING INCISION</b>	<b>6</b>
2.1 Patient preparation and Quadriceps Tendon exposure	6
2.2 Vertical Cutter introduction and advancement	6
<b>3. HORIZONTAL HARVESTING INCISION</b>	<b>7</b>
3.1 Horizontal Cutter introduction and advancement	7
<b>4. PROXIMAL TRANSECTION</b>	<b>8</b>
4.1 Subcutaneous Cutter introduction and advancement	8
<b>5. SUBCUTANEOUS CUTTER CLEANING INSTRUCTIONS</b>	<b>9</b>
<b>6. INSTRUMENTS NOMENCLATURE</b>	<b>10</b>

## 1. INSTRUMENTS OVERVIEW

### 1.1 VERTICAL CUTTERS

The MectaQTH Vertical Cutters are used to create parallel subcutaneous incisions of the Quadriceps Tendon (QT) over a defined length for graft harvesting. The width (W) of the incision is variable while the depths (H) are defined to either 5 mm or 7 mm and a combination of these dimensions creates a portfolio of cutters that address the various surgical indications (ACL, PCL or MPFL).

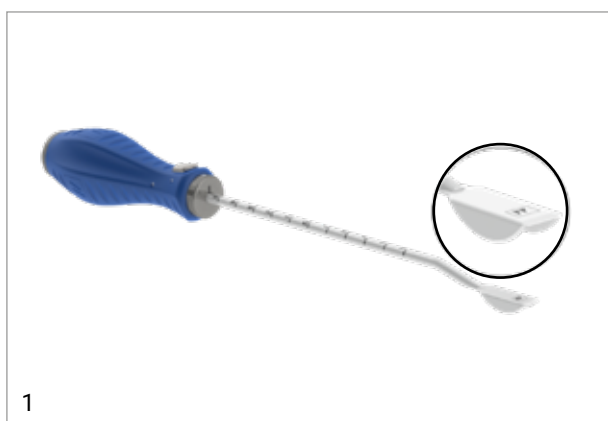

This portfolio is shown in the table below. Furthermore, dedicated configurations for the M-ARS ACL surgical technique are available. The length of the harvesting can be measured by the graduated scale on the cutter shafts. These disposable cutters are coupled with a reusable ergonomic handle that assists handling and ensures steady and consistent incision.

<b>VERTICAL</b> Cutting Blades WxH (mm)
8x5
8x7
9x5
9x7
10x5
10x7
12x5
12x7
14x5
14x7
<b>12.5x5 (Small)*</b>
<b>14.2x5.5 (Medium)*</b>
<b>15.2x6 (Large)*</b>

\*For M-ARS ACL

### 1.2 HORIZONTAL CUTTERS

The MectaQTH Horizontal Cutters are used to create horizontal subcutaneous incisions of the Quadriceps Tendon (QT) over a defined length for graft harvesting. The width (W) and depth (H) of the incisions are available in different configurations depending on the surgical indications (ACL, PCL or MPFL).

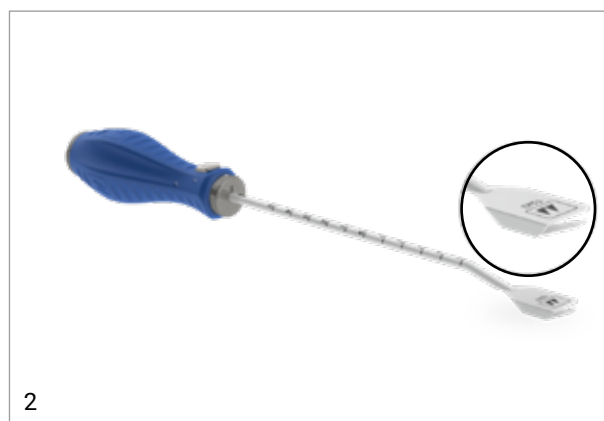

This portfolio is shown in the table below. Furthermore, dedicated configurations for the M-ARS ACL surgical technique are available. The length of the harvesting incision can be measured by the graduated scale on the cutter shafts. These disposable cutters are also coupled with a reusable ergonomic handle that assists handling and ensures steady and consistent incision.

<b>HORIZONTAL</b> Cutting Blades WxH (mm)
10x4
15x3
15x5
15x6
<b>15x4.5 (Small)*</b>
<b>15x5 (Medium)*</b>
<b>15x5.5 (Large)*</b>

\*For M-ARS ACL

### 1.3 SUBCUTANEOUS CUTTERS



The MectaQTH Subcutaneous Cutter is used to perform the proximal cutting of the graft at a defined length, thereby freeing the harvested graft portion.

The instrument is designed to insert and secure the graft within the slotted tip during proximal advancement. A secure locking mechanism within the handle prevents premature cutting of the graft. The instrument is available in two configurations, Small (color code: gold) and Large (color code: black), which are individually used to incise the smaller and larger grafts obtained using the Vertical and Horizontal Cutters.

### 1.4 VERTICAL, HORIZONTAL AND SUBCUTANEOUS CUTTER COMBINATIONS

The MectaQTH instruments have been designed in specific configurations to ensure the optimal grafts sizes are harvested for the selected surgical indications (ACL, PCL or MPFL reconstruction).

The table shows the combinations between the Vertical and Horizontal Cutters as well as the dedicated Subcutaneous Cutter used to perform the final transection.

#### WARNING

Only combine the dedicated instruments as indicated in the table.

#### CAUTION

The dimensions of the harvested graft should be carefully evaluated by the surgeon, based on the intended successive procedure and on the assessment of the original tendon, to avoid excessive weakening that may result in unsuccessful outcomes.

		HORIZONTAL CUTTERS						
		15x3	10x4	15x5	M-ARS ACL SMALL	M-ARS ACL MEDIUM	15x6	M-ARS ACL LARGE
VERTICAL CUTTERS	8X5	Light Blue						
	8X7						Light Blue	
	9X5	Light Blue						
	9X7						Light Blue	
	10X5	Light Blue						
	10X7						Dark Blue	
	12X5	Light Blue		Dark Blue				
	12X7	Light Blue		Dark Blue			Dark Blue	
	M-ARS ACL SMALL				Light Blue			
	14X5	Light Blue		Dark Blue				
	14X7	Light Blue		Dark Blue			Dark Blue	
	M-ARS ACL MEDIUM					Dark Blue		
	M-ARS ACL LARGE							Dark Blue

<span style="display:inline-block; width:15px; height:10px; background-color:lightblue; border:1px solid black;"></span>	<b>SUBCUTANEOUS CUTTER SMALL</b>
<span style="display:inline-block; width:15px; height:10px; background-color:darkblue; border:1px solid black;"></span>	<b>SUBCUTANEOUS CUTTER LARGE</b>
<span style="display:inline-block; width:15px; height:10px; background-color:lightgrey; border:1px solid black;"></span>	<b>NOT FOR USE IN COMBINATION</b>

## 2. VERTICAL HARVESTING INCISION

### 2.1 PATIENT PREPARATION AND QUADRICEPS TENDON EXPOSURE

The patient is positioned to allow free motion of the knee between 0° and 120°. With a knee flexion of 90°, a transverse skin incision of approximately 2.5-3 cm is made over the superior pole of the patella, along the midline centrally for ACL or PCL or superomedially for MPFL. The prepatellar bursa has to be incised longitudinally and the patellar aponeurosis carefully exposed. A Langenbeck retractor can be used to expose the quadriceps tendon subcutaneously and proximally to the patella.



4

### 2.2 VERTICAL CUTTER INTRODUCTION AND ADVANCEMENT

The Vertical Cutter defines the width of the graft to be harvested. Once the appropriate cutter of desired width and depth (depending on M-ARS ACL, ACL, PCL or MPFL indication) is selected, it has to be coupled with the dedicated handle by pressing the button down and inserting the cutter as shown.

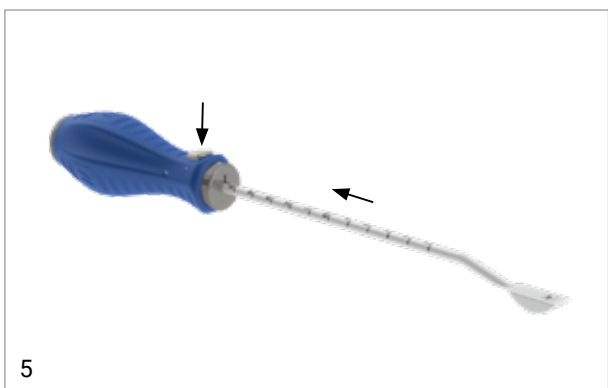

5

The tip of the cutter is introduced through the skin incision and inserted into the QT at the superior patellar border. It is important to ensure that the roof of the cutter is flat and in contact with the QT, this can be achieved by applying a slight pressure on the tip of the cutter or on the cutter's shaft.

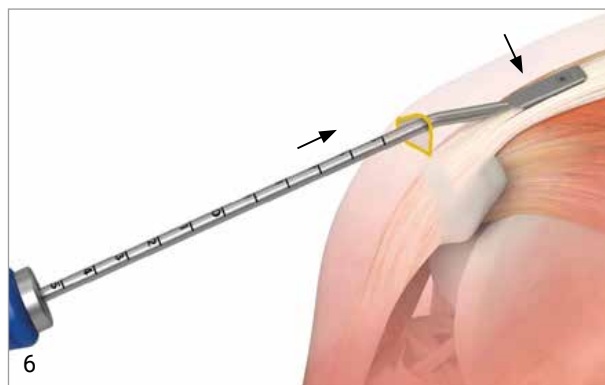

6

The cutter is advanced subcutaneously, in the proximal direction, through the tendon until the vertical incision is of the desired length (ACL 6-7 cm, PCL 7-8 cm, MPFL 8-9 cm, in average). In order to control the length of the incision the graduated measurement scale along the cutter's shaft can be used, referencing the proximal border of the patella. The width and length of the harvested graft is now defined. The tendon is not yet completely incised but is incised only vertically to a depth of up to 5 mm (MPFL) or 7 mm (ACL, PCL).



7

Dedicated M-ARS ACL vertical cutters transect the tendon for use with the specific M-ARS ACL surgical technique.

### 3. HORIZONTAL HARVESTING INCISION

#### 3.1 HORIZONTAL CUTTER INTRODUCTION AND ADVANCEMENT

The Horizontal Cutter defines the thickness of the graft and is selected according to the surgical indication, corresponding to the previously used Vertical Cutter. Once the appropriate horizontal cutter is selected, it is coupled with the dedicated handle by pressing the button down and inserting the cutter as shown.

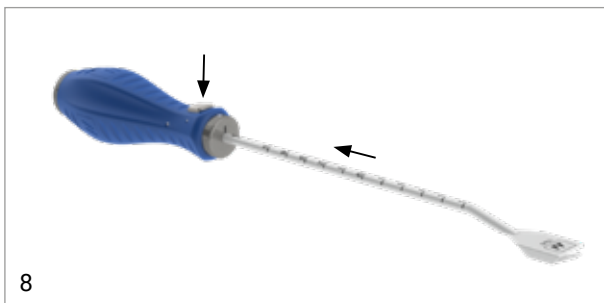

With the knee still at 90° flexion, insert the tip of the horizontal cutter through the skin incision and using the v-shaped cutting edge, insert the cutter into the harvested portion of the graft at the proximal border of the patella as shown. Ensure the roof of the cutter is flat and in contact with the quadriceps tendon.



The cutter is advanced proximally and subcutaneously to the same length, as defined by the Vertical Cutter, in order to detach a portion of the tendon. In order to control the length of the incision the graduated measurement scale along the cutter's shaft can be used, referencing the proximal border of the patella. To facilitate the advancement of the cutter, minimal back and forth shuffling movements are recommended. The harvested graft strip is now freed from the native QT but remains attached at its proximal and distal ends.

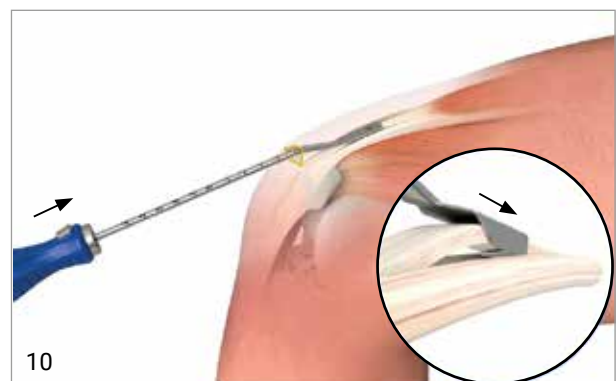

**NOTE:** during advancement the roof of the cutter must remain pressed to the QT.

## 4. PROXIMAL TRANSECTION

### 4.1 SUBCUTANEOUS CUTTER INTRODUCTION AND ADVANCEMENT

With the knee at 90° flexion, keeping the Subcutaneous Cutter fully opened, insert the tip of the instrument through the skin incision. Thereafter, insert the harvested graft strip into the open slot of the instrument's tip as shown.

**NOTE:** ensure the entire strip is within the slotted tip.

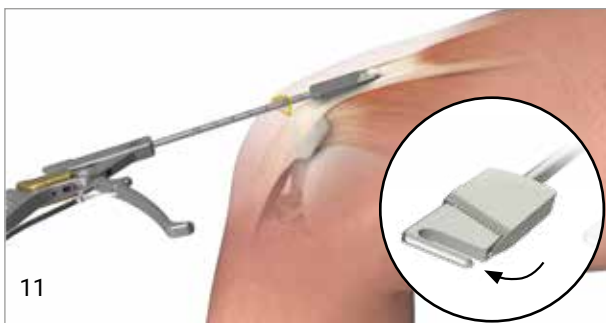

With the harvested graft strip inserted into the slotted tip, depress the handle of the instrument to lock the graft strip within the dedicated slot using the protruding portion of the instrument's cutting blade. At this point, the handle locking mechanism blocks the instrument preventing further closure (i.e. cutting is prevented) or reopening (i.e. freeing the ligament).

**NOTE:** ensure the entire strip is within the slotted tip prior to progress.



Advance the instrument proximally up to the corresponding length (as defined by the Vertical and the Horizontal Cutters), checking the graduated measurement scale along the cutter's shaft. The length should be measured referencing the proximal border of the patella.

Once the instrument has been inserted to the desired length, the locking mechanism slider is retracted as shown, freeing the handle and allowing the final cut to be performed.



The QT is now cut proximally and can be pulled out through the skin incision. The distal attachment can be incised using standard instruments completing the harvesting procedure.



## 5. SUBCUTANEOUS CUTTER CLEANING INSTRUCTIONS

To clean the cannulated portions of the subcutaneous cutter please follow the following instructions:

Retract the locking mechanism slider (in gold) and press the handle to reach the cutting configuration of the device. Keeping the instrument in this position, wash the instrument from the opening located at the bottom of the central body (as represented).







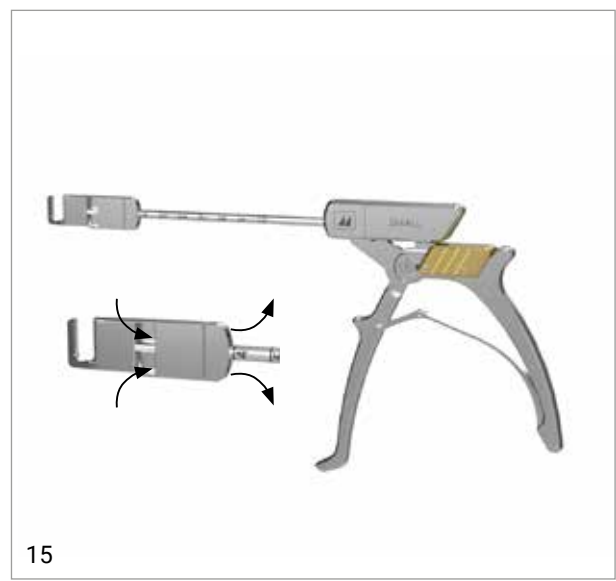















The water will flow out from the holes at the back of the tip.

Open the instrument exposing the tip of the cutter (as represented).

Wash the instrument from the anterior opening of the tip. The water will flow out from the holes at the back of the tip.



## 6. INSTRUMENTS NOMENCLATURE

REF. NO.	DESCRIPTION	PICTURE
05.05.10.0092	Subcutaneous Cutter Small	
05.05.10.0114	Subcutaneous Cutter Large	
05.05.10.0093	Small Screwdriver – Rotation Locking	
05.05.10.0094	Vertical Cutter – 8x5	
05.05.10.0095	Vertical Cutter – 8x7	
05.05.10.0096	Vertical Cutter – 9x5	
05.05.10.0097	Vertical Cutter – 9x7	
05.05.10.0098	Vertical Cutter – 10x5	
05.05.10.0099	Vertical Cutter – 10x7	
05.05.10.0100	Vertical Cutter – 12x5	
05.05.10.0101	Vertical Cutter – 12x7	
05.05.10.0102	Vertical Cutter – 14x5	
05.05.10.0103	Vertical Cutter – 14x7	
05.05.10.0104	Vertical Cutter – MARS ACL SMALL	
05.05.10.0105	Vertical Cutter – MARS ACL MEDIUM	
05.05.10.0106	Vertical Cutter – MARS ACL LARGE	
05.05.10.0107	Horizontal Cutter – 10x4	
05.05.10.0108	Horizontal Cutter – 15x3	
05.05.10.0109	Horizontal Cutter – 15x5	
05.05.10.0110	Horizontal Cutter – 15x6	
05.05.10.0111	Horizontal Cutter – MARS ACL SMALL	
05.05.10.0112	Horizontal Cutter – MARS ACL MEDIUM	
05.05.10.0113	Horizontal Cutter – MARS ACL LARGE	

Part numbers subject to change.

## **NOTE FOR STERILISATION**

Only Vertical and Horizontal Cutters are delivered sterile. The reusable instruments must be cleaned before use and sterilised in an autoclave noting the regulations of the country, EU directives where applicable and following the instructions for use of the autoclave manufacturer. For detailed instructions please refer to the document "Recommendations for cleaning decontamination and sterilization of Medacta International orthopaedic devices" available at [www.medacta.com](http://www.medacta.com).



---

**REDEFINING BETTER  
IN ORTHOPAEDICS  
AND SPINE SURGERY**

---

MEDACTA.COM



**Medacta International SA**  
Strada Regina - 6874 Castel San Pietro - Switzerland  
Phone +41 91 696 60 60 - Fax +41 91 696 60 66  
info@medacta.ch

Find your local dealer at: [medacta.com/locations](https://www.medacta.com/locations)

All trademarks and registered trademarks are the property of their respective owners.  
This document is not intended for the US market.  
Please verify approval of the devices described in this document with your local Medacta representative.

Quad Tendon Harvesting System  
Surgical Technique

Ref: 99.107SMK.12  
rev. 01

Last update: April 2019  
**€ 2797**